

## Measurement of bed load in rivers

WILLIAM W. EMMETT

US Geological Survey, Box 25046, MS 413, DFC,  
Lakewood, Colorado 80225, USA

**ABSTRACT** The Helley-Smith bed load sampler is a direct measuring, pressure differential sampler designed for use with sediment ranging in size from coarse sand to medium gravel. For sediment particle sizes between 0.50 and 16 mm, the Helley-Smith bed load sampler has a near-perfect sediment trapping efficiency. For particle sizes smaller than 0.50 mm or larger than about 16 mm, inadequate calibration data exist to establish valid sampling efficiencies. An adequate sampling procedure for many rivers consists of sampling bed load at about 20 equally-spaced transverse locations on each of two traverses across the river. This procedure enables determination of mean bed load transport rate as well as providing insight to spatial and temporal variations in transport rate.

### Mesure du charriage de fond des cours d'eau

**RESUME** L'appareil à prélever les transports de fond de Helley-Smith effectue une mesure directe, utilisant la pression différentielle. Il a été conçu pour les sédiments dont la granulométrie varie depuis le sable grossier jusqu'au gravier moyen. Pour les classes de particules de sédiment comprisés entre 0.50 et 16 mm, l'appareil Helley-Smith a une efficacité de prélèvement presque parfaite. Pour les classes de particules plus petites que 0.50 mm ou plus grandes que 16 mm environs, les données d'étalonnage sont insuffisantes pour déterminer valablement l'efficacité de l'appareil. Une méthode d'échantillonnage suffisante pour beaucoup de rivières consiste à prendre des échantillons des sédiments de fond à environs 20 emplacements également espacés sur un profil en travers et à répéter cette mesure sur un second profil en travers. Ce procédé permet de déterminer la vitesse de transport moyenne du sédiment de fond en même temps elle fournit un aperçu sur les variations spatiales et temporelles des transports de fond.

## INTRODUCTION

Bed load is that sediment carried down a river by rolling and saltation on or near the stream bed. Though bed load may best be defined as that part of the sediment load supported by frequent solid contact with the unmoving bed, in practice it is the sediment moving on or near the stream bed rather than in the bulk

of the flowing water.

In the sediment transport process, individual bed material particles are lifted from the stream bed and set into motion. If the motion includes frequent contact of a particle with the stream bed, the particle constitutes part of the bed load. If the motion includes no contact with the stream bed, the particle is literally a part of the suspended load, regardless of how close to the stream bed the motion occurs. Depending on the hydraulics of flow in various reaches of a channel, particles may alternate between being a part of the bed load or a part of the suspended load. At a given cross section of channel, particles that are part of the bed load at one stage may be part of the suspended load at another stage. Any particle in motion may come to rest; for bed load, downstream progress is likely to be a succession of movements and rest periods. Particles at rest are part of the bed material. Obviously, there is an intimate relation between bed material, bed load, and suspended load.

Owing to the somewhat nebulous definition of bed load, it becomes an exceedingly difficult task to build measuring equipment which samples only bed load. Any device which rests on the stream bed is perilously close to sampling bed material, and any device which protrudes upward from the stream bed, or by necessity is raised or lowered through the flow, may sample some part of the suspended load.

#### HELLEY-SMITH BED LOAD SAMPLER

Helley & Smith (1971) introduced a pressure difference bed load sampler that is a structurally modified version of the Arnhem sampler. The Helley-Smith bed load sampler has an expanding nozzle, sample bag, and frame (Figs 1 and 2). The sampler was designed to be used in flows with mean velocities up to  $3 \text{ m s}^{-1}$  and sediment sizes from 2 to 10 mm. The sampler has a square 7.62 cm entrance nozzle and a 46 cm long sample bag constructed of 0.25 mm mesh polyester. The standard sample bag has a surface area of approximately  $1900 \text{ cm}^2$ .

The original design included a brass nozzle, aluminium tubing frame weighted with poured melted lead to a total weight of 30 kg, aluminium tail fins, and bolted construction. More recent versions of the sampler have stainless steel nozzles for greater durability, steel plate tail fins, solid steel round stock bar frame selected to maintain a 30 kg total weight, and welded construction. The sample bag attaches to the rear of the nozzle with a rubber "O" ring. A sliding bracket on the top frame member allows for cable suspended lowering and raising of the sampler. The position of the bracket along the frame controls the sampler attitude; normal attitude is a slightly tail heavy position (about a  $15^\circ$  angle).

An extensively used version of the sampler has the nozzle and sample bag adapted to a wading rod, rather than having a frame and tail fin assembly. To minimize weight and facilitate use of this model, the nozzle is generally of cast aluminium and equipped with a sectionalized tubular aluminium wading rod.

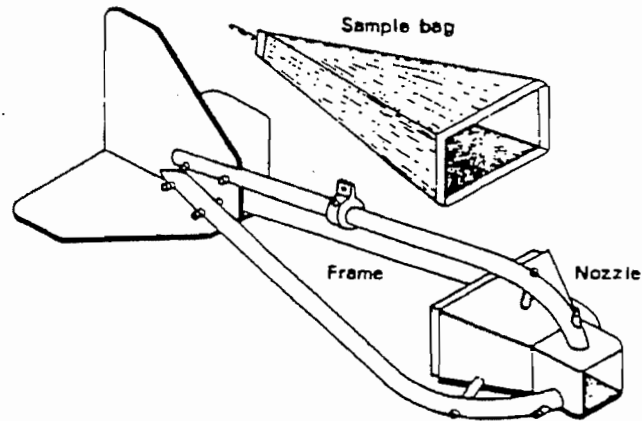

Fig. 1 Helley-Smith bed load sampler.

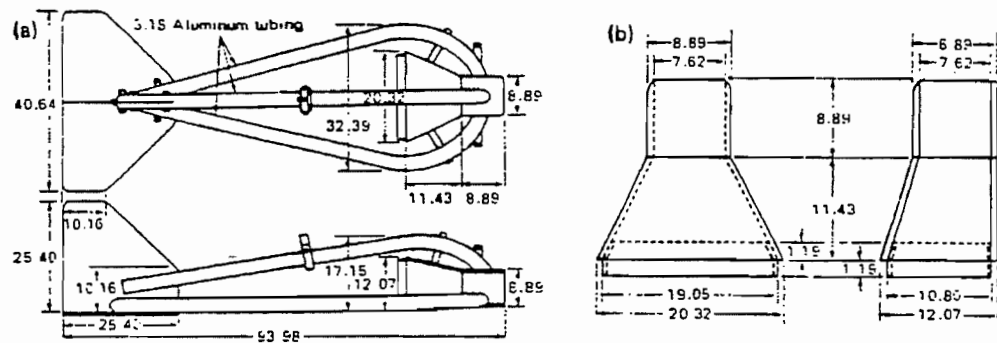

Fig. 2 Plan and side elevation drawings of (a) 7.62 cm Helley-Smith bed load sampler, and (b) sampler nozzle. All dimensions in centimetres.

Other versions of the sampler include a twice scale or 15.2 cm square nozzle, and a heavier frame to give a total weight of 75 kg.

#### CALIBRATION OF THE BED LOAD SAMPLER

Hydraulic efficiency of a bed load sampler is defined as the ratio of the mean velocity of water discharge through the sampler to the mean velocity of the water discharge which would have occurred through the area occupied by the opening in the sampler nozzle had the sampler not been there.

A laboratory hydraulic calibration of the Helley-Smith bed load sampler was conducted at the US Geological Survey Gulf Coast Hydroscience Center (Druffell et al., 1976). In the laboratory study, velocity profiles were measured in the sampler nozzle and at various locations upstream from the sampler. The results of this study showed that the hydraulic efficiency of the Helley-Smith bed load sampler is approximately 1.54. This value of hydraulic efficiency was found to be constant for the range of flow conditions in the experiments, a range applicable to many natural streamflow conditions.

The study, along with field observations by the writer,

indicates that the sample bag can be filled to about 40% capacity with sediment larger than the mesh size of the bag without reduction in hydraulic efficiency. However, sediment with diameters close to the mesh size of the sample bag both plugs the sample bag and escapes through the mesh, causing an unpredictable decrease in hydraulic efficiency and loss of the sample.

The sampling efficiency of a bed load sampler is defined as the ratio of the weight of bed load collected during a sampling time to the weight of bed load that would have passed through the sampler width in the same time, had the sampler not been there. Ideally, the ratio is 1.0, and the weight of every particle size fraction in the collected sample is in the same proportion as in the true bed load.

A field calibration of the sediment trapping characteristics of the Helley-Smith bed load sampler was conducted at the US Geological Survey Bed Load Transport Research Facility on the East Fork River, Wyoming (Emmett, 1980). An open slot across the stream bed of the East Fork River, continually evacuated of trapped debris by a conveyor belt, provided a bed load trap and direct quantitative measurement of bed load transport rates for comparison with bed load transport rates measured with the Helley-Smith bed load sampler.

Composition of the stream bed of the East Fork River at the bed load trap is primarily sand, but gravel bars are spaced at regular intervals of about 5 to 7 channel widths. Composite size distribution data of a number of bed material samples are listed in Table 1 and show ample availability of bed material for particles ranging in size from 0.25 to 32 mm. For each bed load transport rate measured at the conveyor belt bed load trap, detailed particle size analyses of the trapped sediment provided size composition data of the bed load. For comparison with the bed material size data, Table 1 also lists a transport weighted particle size distribution for the whole of the bed load sampled in 1976. The median particle size of bed load is 1.13 mm compared to 1.25 mm for bed material.

Although the median particle sizes of bed load and bed material are nearly the same, the bed material consists of some larger particles that are rarely moved. For bed load and bed material, Table 2 lists particle size at given particle size categories (given percentage, by weight, finer than values). Table 2 clearly indicates that some bed material particle sizes are seldom involved in the sediment transport process, a factor which limited the reliability of the calibration to particle sizes smaller than about 16 mm.

In the field calibration tests, 24 cross-channel sections constituted the transverse frequency of sampling. Two traverses of the stream yielded 48 individual Helley-Smith type samples; these were averaged to give a mean bed load transport rate, and used in the comparison with a mean bed load transport rate for the conveyor belt sampler. The Helley-Smith sampler was lowered by cable to the stream bed, timed for a duration of 30 s, and retrieved. Generally, each bed load sample was individually bagged and later air-dried, sieved, and weighed. Data thus collected could be later composited across the entire stream

**Table 1** Size distribution of composited bed material and of transport-weighted composite bed load, East Fork River, Wyoming, at bed load transport research project

Sieve diameter (mm)	Percentage, by weight, retained on sieve		Percentage, by weight, finer than sieve	
	Bed material	Bed load	Bed material	Bed load
Pan	0.3	0.3	0.0	0.0
0.062	0.1	0.1	0.3	0.3
0.088	0.4	0.2	0.4	0.4
0.125	1.0	0.4	0.8	0.6
0.177	2.4	1.0	1.8	1.0
0.250	6.6	5.3	4.2	1.9
0.350	12.0	11.8	10.8	7.2
0.500	13.5	15.1	22.8	19.0
0.710	9.1	11.8	36.2	34.1
1.00	7.4	11.9	45.3	45.9
1.40	6.1	12.0	52.7	57.8
2.00	4.7	9.9	58.8	69.9
2.80	4.3	7.4	63.5	79.8
4.00	3.6	5.5	67.8	87.2
5.60	3.6	3.4	71.4	92.7
8.00	3.6	1.8	75.0	96.1
11.3	4.3	1.0	78.5	97.9
16.0	4.1	0.5	82.8	98.9
22.6	5.1	0.4	86.9	99.4
32.0	5.2	0.2	92.9	99.8
45.0	2.8	0.0	97.2	100.0
64.0	0.0		100.0	

**Table 2** Comparison of bed material and bed load particle sizes

Particle size category (d % finer than)	Particle size (mm)	
	Bed material	Bed load
d <sub>5</sub>	0.27	0.32
d <sub>16</sub>	0.42	0.47
d <sub>25</sub>	0.53	0.58
d <sub>35</sub>	0.69	0.73
d <sub>50</sub>	1.25	1.13
d <sub>65</sub>	3.20	1.73
d <sub>75</sub>	8.00	2.37
d <sub>84</sub>	17.6	3.42
d <sub>95</sub>	37.6	7.01

width for a comparison with the conveyor belt data.

All basic data of the field calibration tests have been summarized earlier (Emmett, 1980). Relationships between the bed load transport rate in each particle size class and total bed load transport rate were determined for both methods of sampling. The statistical procedure utilized was a least squares linear regression of log transformed data, giving a power equation of the form

$$Y = AX^B$$

where Y is the bed load transport rate in a given particle size class and X is the total bed load transport rate.

**Table 3** Mean percentage of total bed load in each particle size class and rate of change in percentage as bed load transport rate changes

Particle size class (mm)	Mean percentage of total bed load in particle size class ( $\bar{Y}/\bar{X}$ in %)		Rate of change in percentage of total bed load in particle size class (B)	
	Helley-Smith	Conveyor belt	Helley-Smith	Conveyor belt
0.06- 0.12	0.35	0.32	0.727	0.663
0.12- 0.25	3.24	1.74	0.599	0.553
0.25- 0.50	22.80	18.49	0.698	0.742
0.50- 1.00	26.84	27.89	1.050	1.000
1.00- 2.00	20.07	21.89	1.213	1.173
2.00- 4.00	10.61	13.87	1.344	1.278
4.00- 8.00	3.45	5.56	1.193	1.211
8.00-16.00	0.89	1.49	0.867	0.995
16.00-32.00	0.65	0.74	0.387	0.926

Table 3 lists the percentage of total bed load occurring in each particle size class and the rate of change (slope of the regression equation) in the above percentages as the actual bed load transport rate increases or decreases. Mean percentages in Table 3 do not add to 100 because the mean value,  $\bar{X}$ , for total bed load is variable. That is, larger particles move only during higher transport rates, and the mean value of total bed load is, obviously, greater during those instances. The effect is to decrease the apparent mean percentage of total bed load in the larger particle size classes.

Because the mesh size of the sample collection bag used on the Helley-Smith sampler was 0.25 mm, data of the first two particle size categories tabulated above should be disregarded.

For sediment in the 0.25-0.50 mm particles size class, both samplers retain all sediment which is supplied to them. The Helley-Smith sampler showed a greater mean percentage of total bed load in this size class than did the conveyor belt sampler. Analyses of suspended sediment data showed appreciable quantities of this size sediment in suspension. Certainly the collection of some suspended sediment by the Helley-Smith sampler is an explanation for its greater mean percentage in this size category, but a quantitative description of how much of it is attributable to this effect was not determined. It is most important to recognize that the Helley-Smith sampler does receive suspended sediment and that the absolute quantities of it are dependent on the sizes of sediment in transport and the hydraulic characteristics of the flow, factors which are different for every stream and thus cannot be calibrated.

Complete analysis of suspended sediment data for the East Fork River showed no significant quantity of suspended sediment larger

than 0.50 mm. For material capable of being moved in suspension (<0.50 mm), its significance as bed load decreases as the bed load transport rate increases. This is reflected in the rate of change values (exponent B) tabulated in Table 3. The values for suspended sediment size particles are less than unity, indicating that as total bed load transport rate increases, the percentages of sediment in those size classes decrease.

For sediment in the four particle size classes ranging in size from 0.50 to 8.0 mm, significant bed load transport occurs, and the significance increases as the total bed load transport rate increases. The dominant particle size class of bed load is 0.50-1.0 mm; it accounts for a little over a quarter of the total bed load. The greatest rate of change in percentage of total bed load in a given particle size class occurs for particles in the size class 2.0-4.0 mm, followed by size classes 1.0-2.0 mm and 4.0-8.0 mm. These rates of change values combine with the mean percentage values such that at high bed load transport rates, the percentage of total bed load is greatest in particle size categories of 1.0-2.0 mm and 2.0-4.0 mm. This leads to a median particle size of composited bed load of 1.13 mm (Table 2).

Only about 0.5-2% of the total bed load occurs in the particle size categories of 8-16 mm and 16-32 mm. The transport rate for large particles in the East Fork River was too minimal to allow reliable calibration for particles larger than about 16 mm.

The rate of change data for the two coarsest size categories are misleading. Since the largest particles move only at high transport rates, many low transport runs are not included in the analysis for these size particles. By this fact alone, large particles begin their significance at high transport rates and increase from there. Because zero values cannot be used in log transformed regressions, values of rate of change comparable to the smaller particle size categories cannot be quantitatively determined.

This discussion has concentrated on analysis of bed load transport rates by individual particle size categories as functions of total bed load transport rate. Its primary purpose is to provide some insight into the mechanics of bed load transport and to place reliability limits on the comparability of data collected; it was used to show that for particle sizes less than 0.50 mm, the influence of suspended sediment casts doubts on comparability (not reliability) of data collected with the Helley-Smith sampler. For particle sizes less than 0.25 mm, data collected with the Helley-Smith sampler should be discarded. For particle sizes larger than about 16 mm, paucity of individual particles moving probably prohibits the Helley-Smith sampler from collecting a representative sample, and data should be treated with caution.

Data collected concurrently using both the Helley-Smith sampler and the conveyor belt sampler may be compared directly. Disregarding data for particle sizes smaller than 0.50 mm because of the suspended sediment problem, the comparison for each particle size class was made with the Helley-Smith sampler results, Y, expressed as functions of the conveyor belt sampler results, X.

As in the previous analysis, the statistical procedure utilized was a least squares linear regression of log transformed data, giving a power equation of the form

$$Y = AX^B$$

Salient data of this analysis are given in Table 4.

**Table 4** Summary of basic data\* describing the sediment trapping characteristics of the Helley-Smith bed load sampler

Particle size class (mm)	Coefficient (A)	Rate of change in ratio of transport rate (B)	Mean ratio in transport rate; Helley-Smith: conveyor belt ( $\bar{Y}/\bar{X}$ in %)
0.50- 1.00	0.743	0.934	98.70
1.00- 2.00	0.498	0.868	89.36
2.00- 4.00	0.329	0.803	86.43
4.00- 8.00	0.192	0.739	93.81
8.00-16.00	0.143	0.747	93.58

\*Modifications to the basic data (see text) generally indicate average values of the sampling efficiency range from about 90 to 110%.

For particle sizes between 0.50 and 16 mm, the Helley-Smith sampler traps approximately the same amount of sediment as the conveyor belt sampler. Average sampling efficiency for those particle size classes ( $\Sigma\bar{Y}/\Sigma\bar{X}$ , from original statistics, not  $\Sigma(\bar{Y}/\bar{X})$  from Table 4) is 92.6%. If the analysis were based on values of real momentary transport rather than average values, the effect would be to increase the value of the coefficient, A, by about 8% or to increase average sampling efficiency,  $\Sigma\bar{Y}/\Sigma\bar{X}$ , from 92.6 to 97.9% (see Emmett, 1980). A statistical correction to allow for errors in the independent variable, X, provides a correction factor of 1.07 to be applied to the exponent value, B (see Emmett, 1980). Finally, modifications applied to the data to allow for the operational mode of the conveyor belt (see Emmett, 1980) provide correction factors of 1.49 for the coefficient, A, and 1.06 for the exponent, B, giving a mean sampling efficiency,  $\Sigma\bar{Y}/\Sigma\bar{X}$ , of 107.7%.

Total bed load transport rates measured in the calibration study ranged from about 0.003 to 0.3 kg s<sup>-1</sup> m<sup>-1</sup>, a range typical of many natural rivers. The bed load transport rate in each particle size class varied from about 1 to 25% of the total rate (as indicated in Table 3). For particle size classes between 0.50 and about 16 mm, there is good agreement between the transport rate measured with the Helley-Smith sampler and that measured with the conveyor belt sampler. Average values of the sampling efficiency range from about 90 to 110%.

#### SAMPLING PROCEDURES WITH THE HELLEY-SMITH BED LOAD SAMPLER

Although the Helley-Smith bed load sampler is widely used by the

US Geological Survey, other federal and state agencies, and university and private organizations, it has not been officially sanctioned by the US Federal Inter-Agency Sedimentation Committee, nor certified for its technical performance by the US Geological Survey. This certification is awaiting completion of rigorous laboratory testing of the sediment trapping characteristics of the sampler under direction of the US Geological Survey and the Federal Inter-Agency Sedimentation Committee. Laboratory testing of the sampler probably will not be completed until the mid 1980's.

The spatial or cross-channel variations in bed load transport rates are significant. Frequently, all or most of bed load transport occurs in a narrow part of the total width of channel. Though this narrow width of significant transport is generally stationary, it can shift laterally with changes in hydraulic conditions or sediment characteristics. Therefore, knowledge of where bed load transport has occurred previously is not a criterion for eliminating a portion of channel width from the sampling programme. At least 20 equally spaced, transverse sampling stations are necessary to ensure that zones of both maximum and minimum transport are adequately sampled. (For large rivers and small rivers, the technique may be modified. Sections should not be spaced greater than 15 m apart and there is no apparent need for spacing sections closer than 0.5 m.)

Temporal variations in bed load transport rates may also be large. This variation with time is obvious for the stream channel with movement of dunes. Even in gravel bed rivers with no apparent dunes or migrating bed forms, bed load transport may occur in slugs and show distinct cyclic trends with time. Frequency of the cyclic trend is dependent on the velocity and wavelength of the bed form or slug of sediment. Obviously, a precise procedure would be to sample at each transverse station until a reliable mean transport rate was established at each cross-channel location; however, time requirements prohibit this detail.

The adopted procedure (provisional method of the US Geological Survey) is to conduct two traverses of the stream and to sample at least 20 sections on each traverse. The sampling duration is 30-60 s at each station. The spatial factor is covered by the 20 sections; the temporal factor is covered because of the time expended during a single traverse of the stream and the time lag at each section as the second traverse is conducted. A comparison of values of mean transport rate, determined by multiple traverses of the stream, shows little change in the mean value by the addition of more than two traverses. Further, because of changes in the river hydraulics with time, and with each traverse of the river being time consuming, it is often impossible to conduct more than two traverses of the river and have the data considered as instantaneous. Each sample collected with the Helley-Smith bed load sampler requires about 2-3 min for lowering, sampling, raising, emptying, and moving to a new cross-channel location. A typical traverse thus requires about 1 h; two traverses require about 2 h. This time required to complete the double traverse generally allows a minimum of several cycles

to be sampled. In the cyclic trend of transport, this appears adequate to average temporal variations.

Field studies conducted in 1980 at the East Fork River, Wyoming, research facility confirmed the recommended sampling procedure for that river and probably for many other rivers. Along a 2 km reach of river, 43 measuring sections were established at intervals equivalent to 2-3 channel widths. Thus measuring sections were located in pools, riffles, curves, and straights, and over several repetitions of such channel geometry features. For approximately a 50 day period spanning the spring snowmelt runoff season, measurements at each section included transverse water surface and stream bed elevations, and bed load transport rate. In addition, longitudinal slope was measured and discharge was known. These data were adequate to define the relations of bed load transport rate to discharge at each section as well as to prepare a complete sediment budget or accounting of the movement and storage of sediment within the reach of river.

Over the course of the runoff season, every section showed little net change in its cross-sectional size and shape, and about the same quantity of bed load passed each section, a quantity verified by operation of the bed load trap. But, different relations of bed load transport rate to discharge were determined for each section. In the pool areas, slope and bed load transport rate increased rapidly with increases in discharge and thus yielded a clockwise hysteresis relationship of transport rate with discharge. In the riffle areas, slope and bed load transport increased rapidly with decreases in discharge and yielded a counterclockwise hysteresis relationship of transport rate with discharge. Intermediate reaches of river had transport relations intermediate between the extremes provided by the pool and riffle sections. Movement of individual bedforms past the measurement section was reflected in values of individual bed load measurements, but did not appreciably alter the mean value determined from the multiple samples collected on a complete traverse across the river.

With each section of the river having a unique relationship between bed load transport rate and discharge, and with the uniqueness being a time-dependent function of the hydraulic and channel geometry at each section, definition of the transport relation must be for a specific section. Longitudinal sampling of bed load, even over a short reach of channel may integrate such a variety of relations that the determined relationship, though perhaps capable of predicting annual load, does not realistically describe bed load transport at given locations along the river. As such, the integrated relationship has limited usefulness in understanding processes or in applications such as modelling the behaviour of stream channels.

In summary, the recommended procedure for using the Helley-Smith bed load sampler requires about 20 equally spaced, cross-channel sampling locations. Each location is sampled for a duration of 30-60 s on each of two separate traverses across the river. This procedure enables determination of mean bed load transport rate, as well as providing insight into spatial and temporal variations in transport rate. Based on field and

laboratory tests and observations, the following recommendations are made relative to the sediment trapping characteristics of the Helley-Smith bed load sampler:

(a) The Helley-Smith bed load sampler should not be used in instances where the sample collection bag clogs with sediment about equal in size to the mesh openings in the bag, or with organic debris.

(b) The Helley-Smith bed load sampler should not be used when a reasonable fit between the sampler bottom and stream bed cannot be achieved; unsatisfactory performance may be expected when the stream bed is very irregular or when high amplitude, short wave length bed forms are present.

(c) The Helley-Smith bed load sampler should not be used for measuring bed load transport rates for sediment of particle sizes which also are transported as suspended sediment; this generally restricts use to particle sizes larger than 0.50 mm.

(d) For sediment of particle sizes larger than 0.50 mm and smaller than 16 mm, sediment trapping efficiency of the Helley-Smith bed load sampler may be assumed as 100% with no change in efficiency with changes in transport rate.

(e) Trap efficiency for sediment particles larger than 16 mm was indeterminate in the calibration tests; reasonable sampling efficiency may be assumed for particles somewhat larger than 16 mm, but it is likely that sampling efficiency decreases as particle size approaches nozzle dimensions.

#### EXAMPLES OF RIVER DATA

The Helley-Smith bed load sampler has been used to measure bed load in a variety of rivers ranging in channel size from less than 4 m wide to more than 600 m wide, and transporting bed load ranging in size from medium sand to coarse gravel. Measured transport rates have ranged from zero to about  $0.5 \text{ kg s}^{-1} \text{ m}^{-1}$ . The most complete data set for streams transporting primarily sand-size bed load is the information collected for the calibration reported in this paper. Reference to the original paper (Emmett, 1980) or to the limited discussion in the present paper provides some insight into the bed load transport of sand. The following discussion presents, in graphical form, data from gravel bed rivers.

The Snake and Clearwater rivers in the vicinity of Lewiston, Idaho, are large, gravel bed rivers, somewhat confined because of canyon-like settings. At about bankfull stage, mean depths are about 5 m, mean velocities are about  $2.5 \text{ m s}^{-1}$ , and widths about 150-200 m. Channel slopes are variable with stage, but may be approximated as  $0.001 \text{ m m}^{-1}$  for the Snake River and  $0.0005 \text{ m m}^{-1}$  for the Clearwater River. The bed material is bimodal with modes at medium-coarse sand and medium-coarse gravel. The bimodal supply of bed material is such that for most flows, the mean bed load particle size is in the coarse sand range but at highest flows, the mean bed load particle size abruptly shifts to the medium-coarse gravel range as the rivers are competent to disrupt armouring effects and transport the coarser material.

Sediment transport rates have been measured on the Snake and Clearwater rivers since 1972. Data have been published in a series of basic-data reports and have been summarized by Jones & Seitz (1980). These data are plotted in Fig. 3. Although the two rivers have some separate attributes, their general similarity is such that in Fig. 3, data for the two rivers are plotted together.

Suspended sediment data are reasonably well defined, but are not wholly consistent. This is expected, for the wash load portions of the suspended load come from diverse parts of the drainage area and each tributary system has sediment transport characteristics of its own. Somewhat fewer than two-thirds (approximately one standard deviation) of the data are in the 5-fold range surrounding the best fit relationship.

A best fit relationship for the bed load data can be approximated as about 5% of the best fit relationship for suspended sediment. Indeed, the bed load data are more consistent than the suspended sediment data; more than two-thirds of the bed load data are in the 5-fold range (2-10%) surrounding the 5% relationship.

Only in recent years have bed load data for rivers existed in sufficient quantity and reliability to facilitate a better

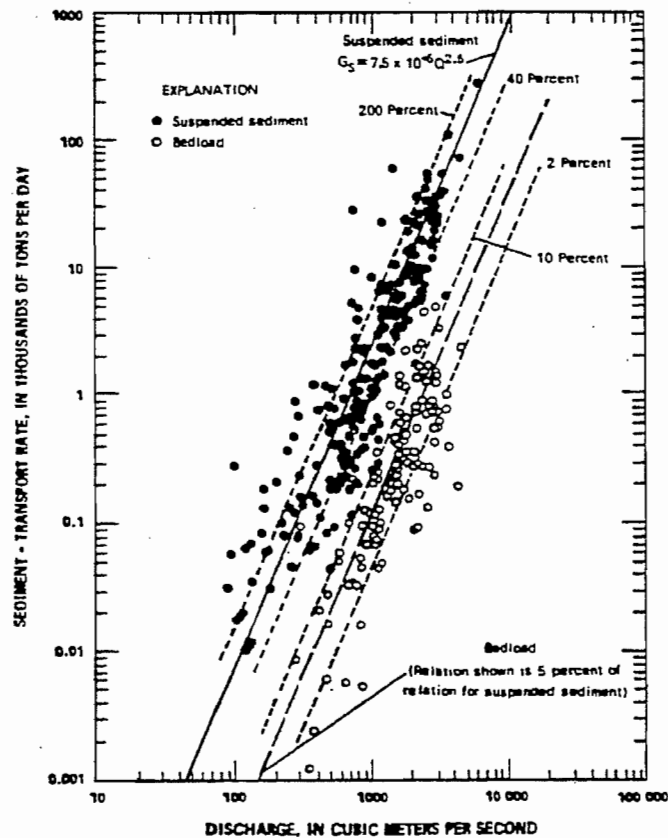

Fig. 3 Sediment transport rate as a function of discharge, Snake and Clearwater rivers in the vicinity of Lewiston, Idaho.

understanding of the bed load transport process. Data for the East Fork River, Wyoming, indicate that when sand-size particles are dominant as bed load, the bed load accounts for about half the total load. The examples of the Snake and Clearwater rivers indicate that for gravel bed rivers, the bed load probably accounts for less than 10% of the total load. But in engineering applications of sediment data, the particle size coarseness of this 10% of the total load may constitute 90% of the design problems involved in the project.

#### REFERENCES

- Druffell, L., Emmett, W. W., Schneider, V. R. & Skinner, J. V. (1976) Laboratory hydraulic calibration of the Helley-Smith bedload sediment sampler. *USGS Open-File Report 76-752*.
- Emmett, W. W. (1980) A field calibration of the sediment-trapping characteristics of the Helley-Smith bedload sampler. *USGS Prof. Pap. 1139*.
- Helley, E. J. & Smith, W. (1971) Development and calibration of a pressure-difference bedload sampler. *USGS Open-File Report*.
- Jones, M. L. & Seitz, H. R. (1980) Sediment transport in the Snake and Clearwater rivers in the vicinity of Lewiston, Idaho. *USGS Open-File Report 80-690*.